



US 20090261723A1

(19) **United States**

(12) **Patent Application Publication**
Chung et al.

(10) **Pub. No.: US 2009/0261723 A1**

(43) **Pub. Date: Oct. 22, 2009**

(54) **ORGANIC ELECTROLUMINESCENT
DISPLAY DEVICE AND FABRICATING
METHOD THEREOF**

(30) **Foreign Application Priority Data**

Apr. 19, 2004 (KR) 2004-0026571

(76) Inventors: **In-Jae Chung**, Gwacheonsi (KR);
Ki-Yong Kim, Gwacheonsi (KR);
Sung-Joon Bae, Seongnamsi (KR);
Jae-Yong Park, Annyangsi (KR)

Publication Classification

(51) **Int. Cl.**
H01L 27/32 (2006.01)
H01L 21/02 (2006.01)

(52) **U.S. Cl.** **313/504; 438/29**

Correspondence Address:
MCKENNA LONG & ALDRIDGE LLP
1900 K STREET, NW
WASHINGTON, DC 20006 (US)

(57) **ABSTRACT**

An electroluminescent display device includes first and second substrates facing each other and having a pixel region and a non-pixel region; a thin film transistor and an array layer on an inner surface of the first substrate; a first electrode on an inner surface of the second substrate; a buffer layer on the first electrode in the non-pixel region; a shielding pattern on the buffer layer; a separator on the shielding pattern; an emitting layer on the first electrode in the pixel region; a second electrode on the emitting layer; and a connection electrode between the first and second substrates.

(21) Appl. No.: **12/457,690**

(22) Filed: **Jun. 18, 2009**

Related U.S. Application Data

(62) Division of application No. 11/107,875, filed on Apr. 18, 2005, now Pat. No. 7,560,863.

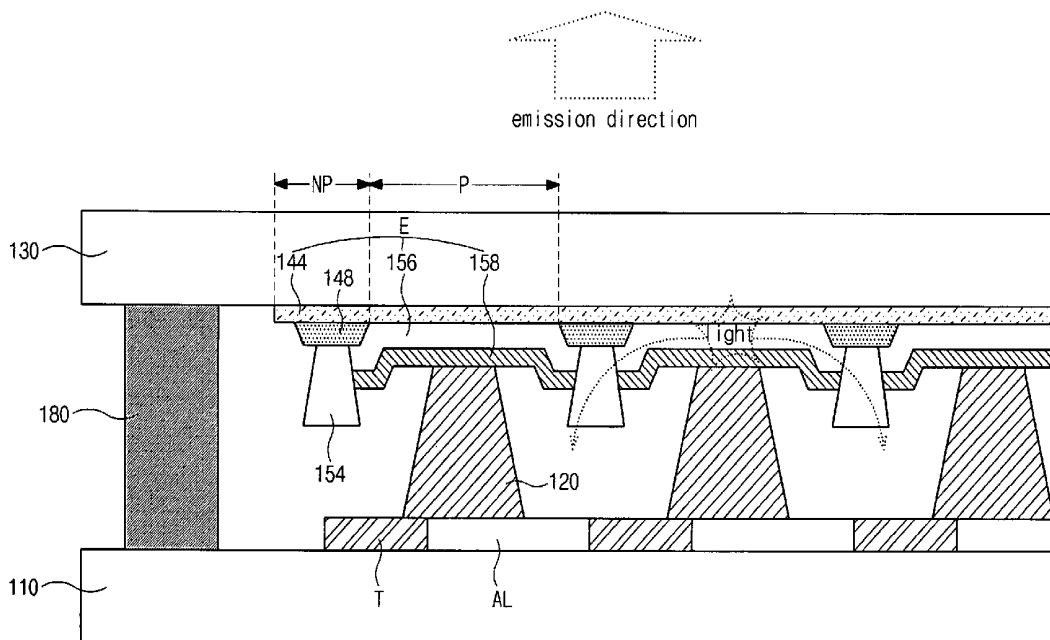

FIG. 1
RELATED ART

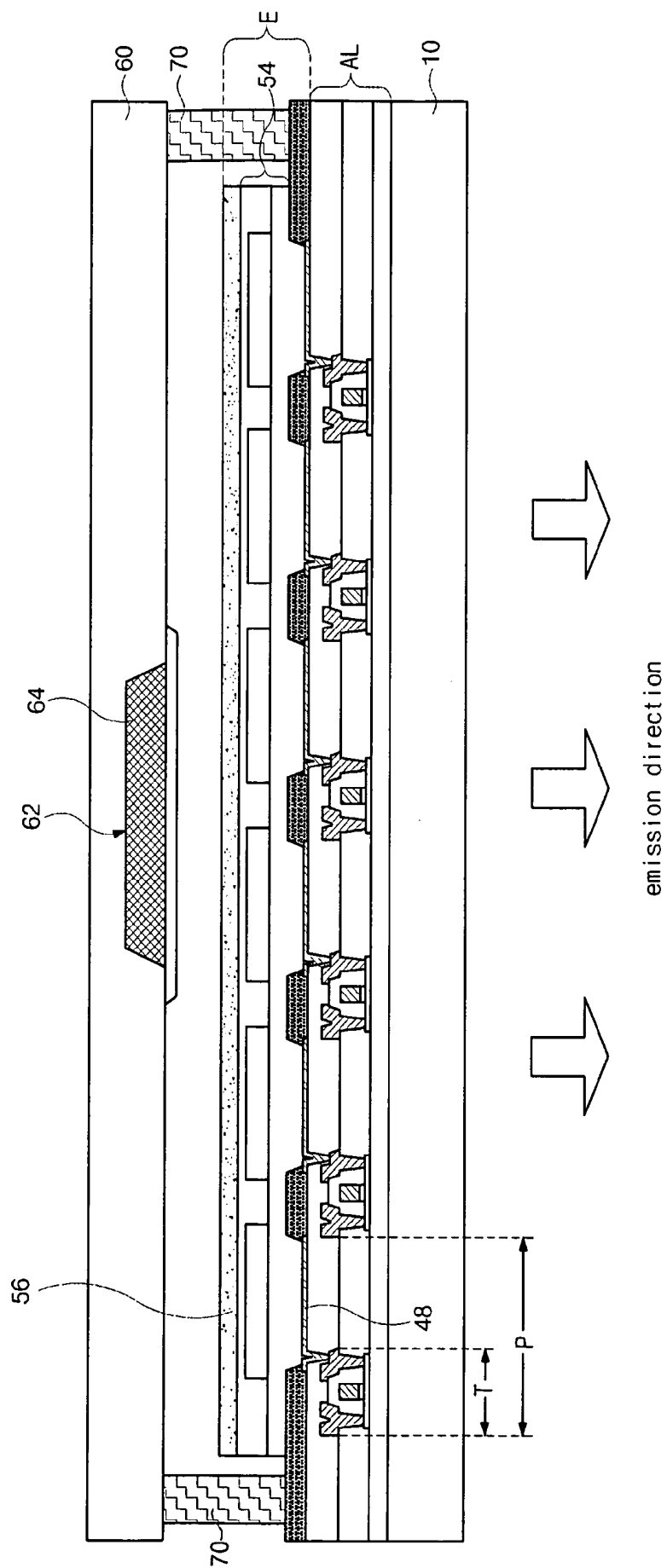

FIG. 2B
RELATED ART

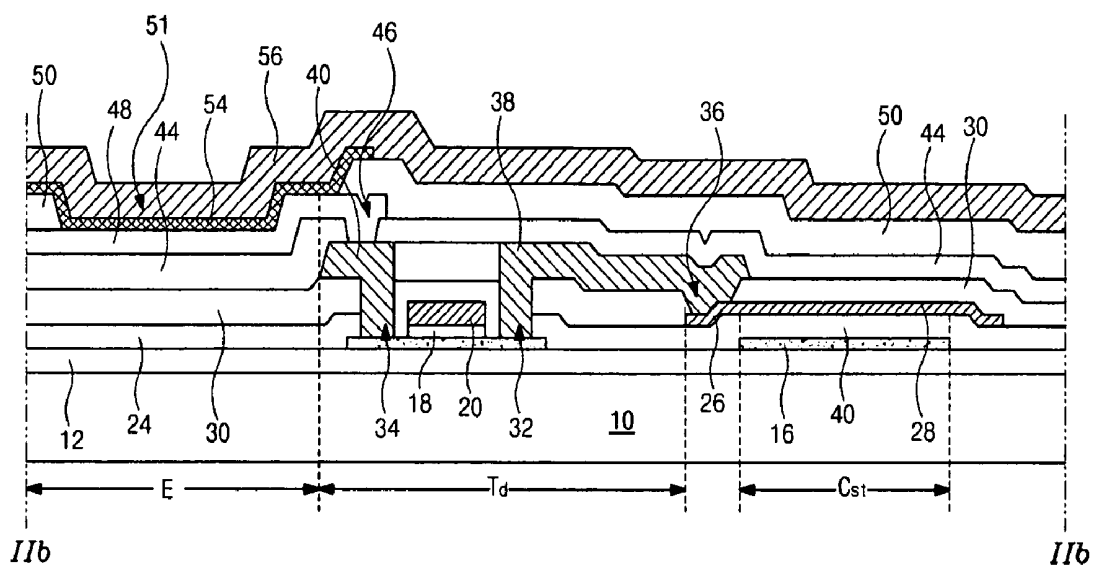

FIG. 3

emission direction

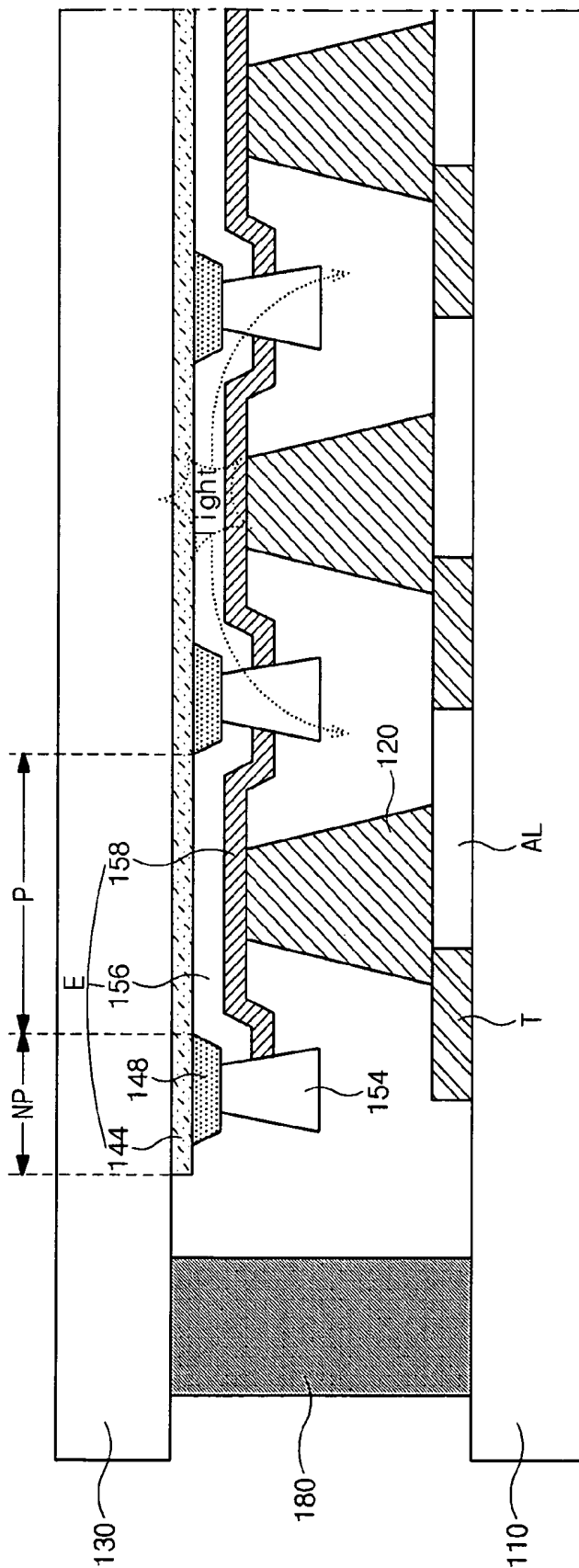

FIG. 4

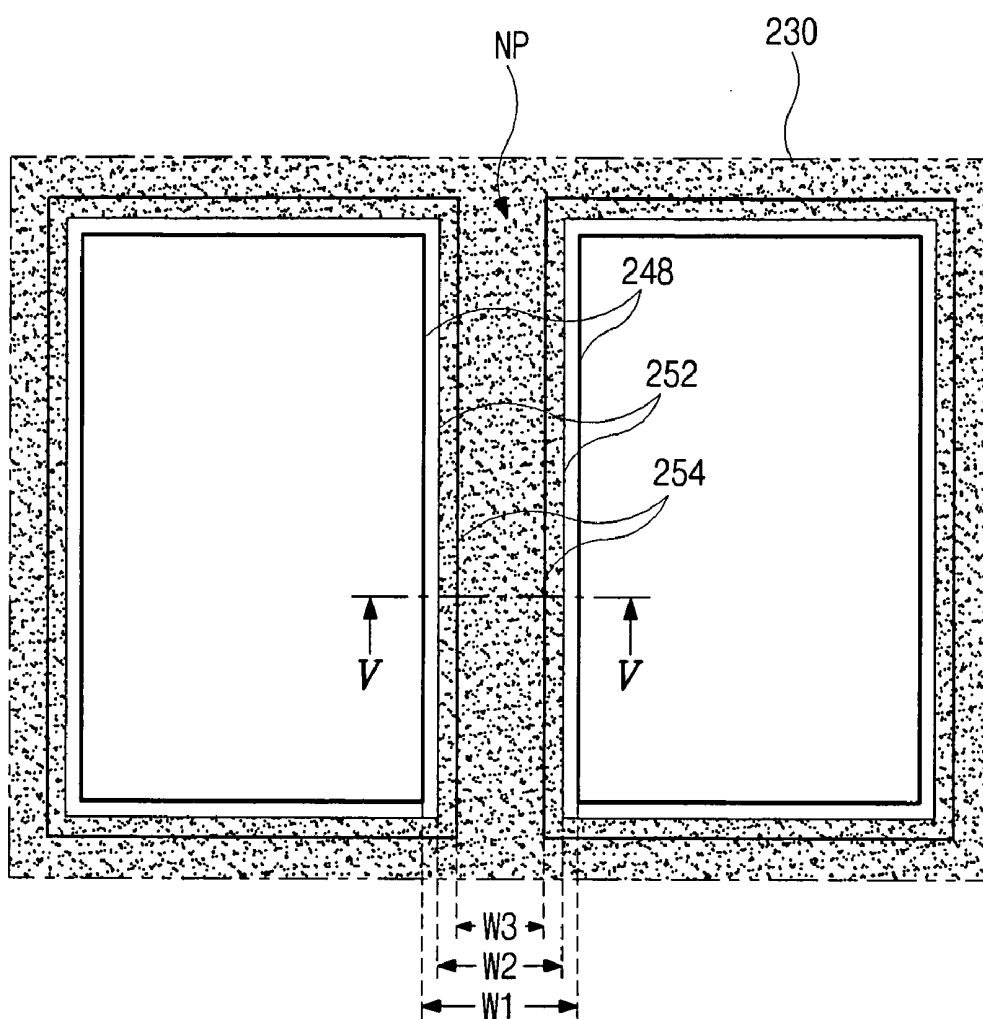

FIG. 5

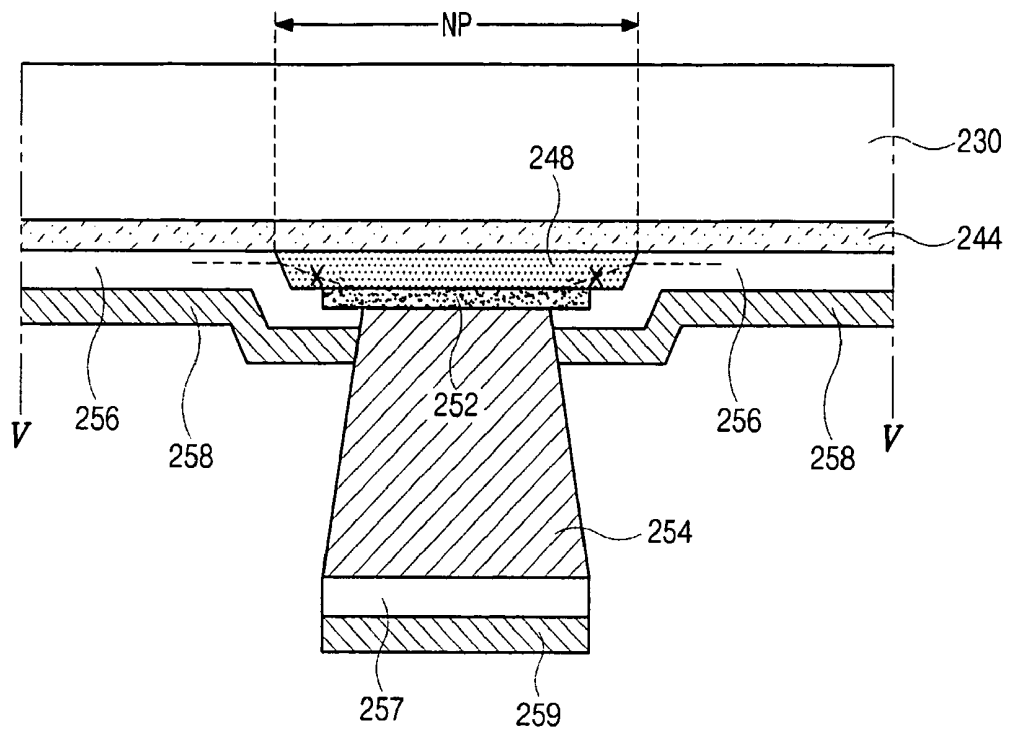

FIG. 6

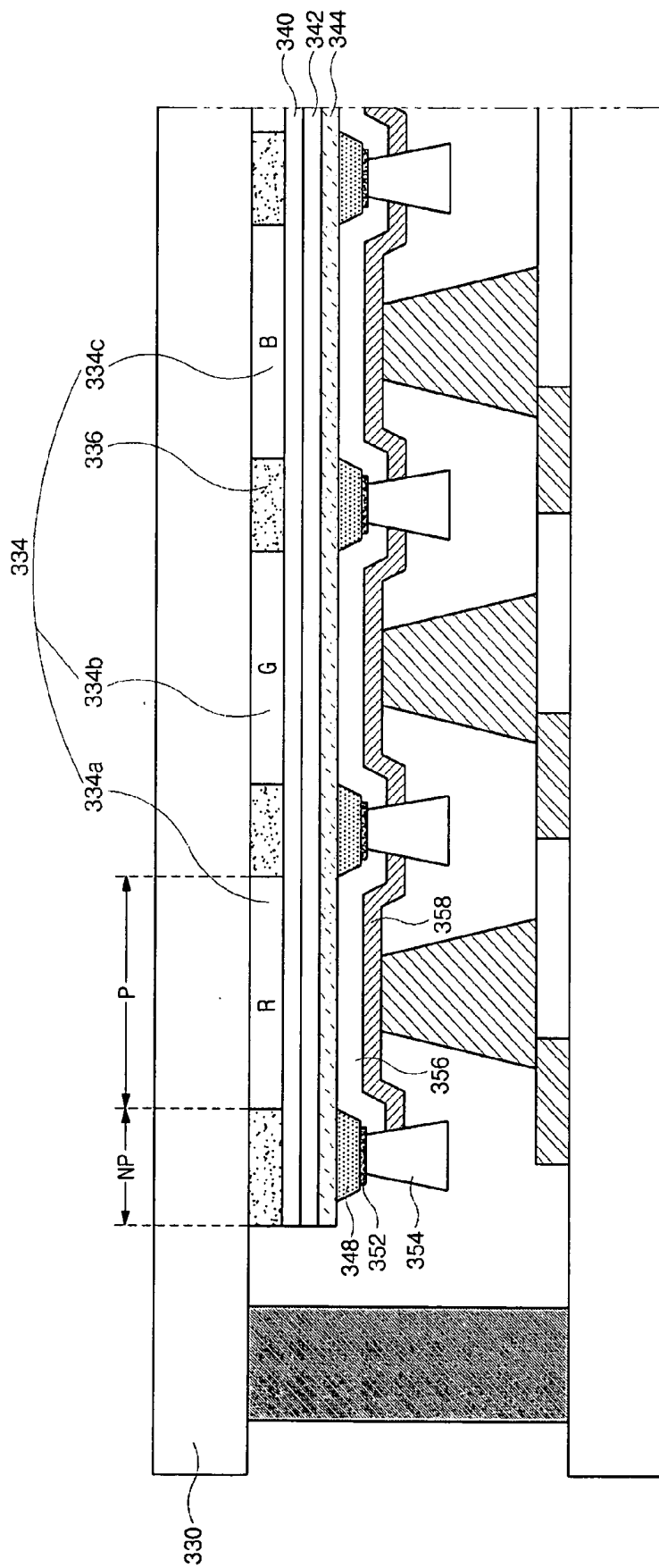

FIG. 7

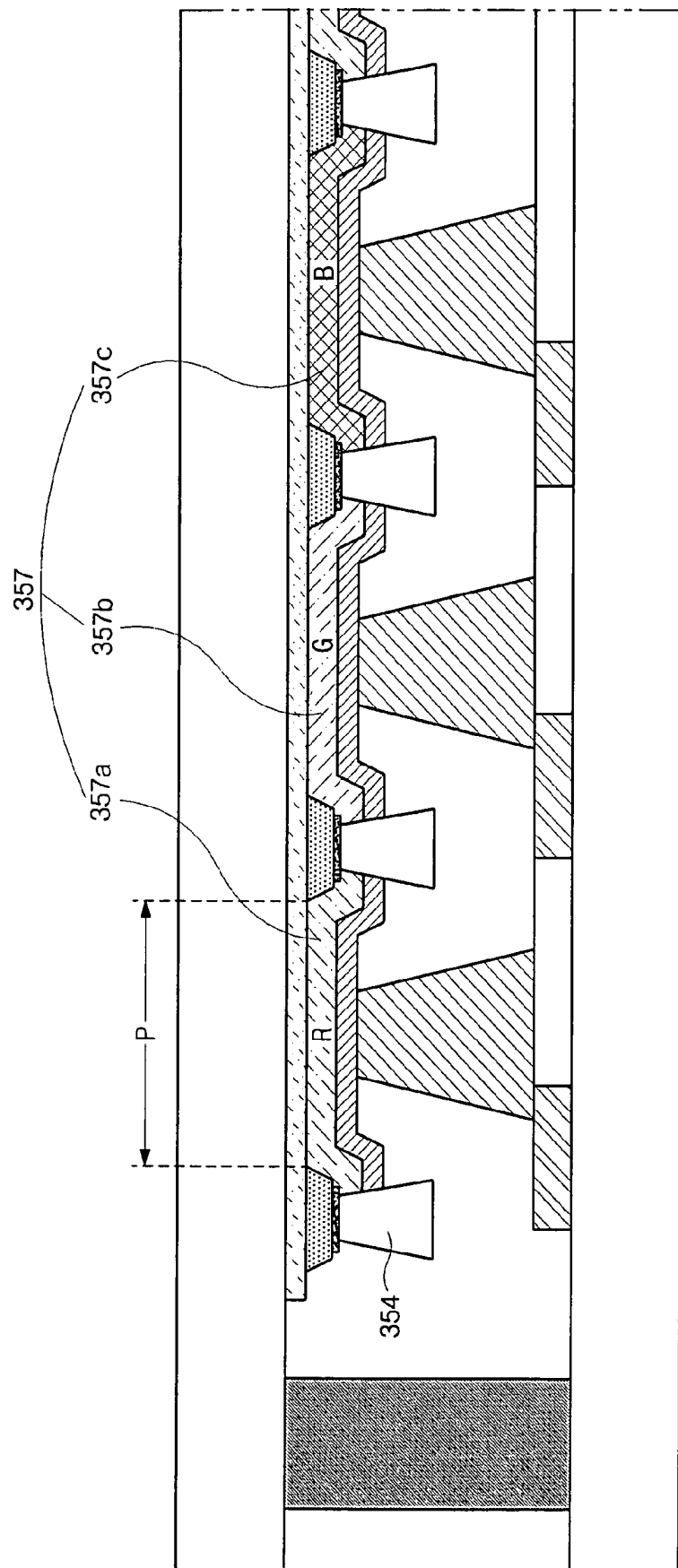

FIG. 8

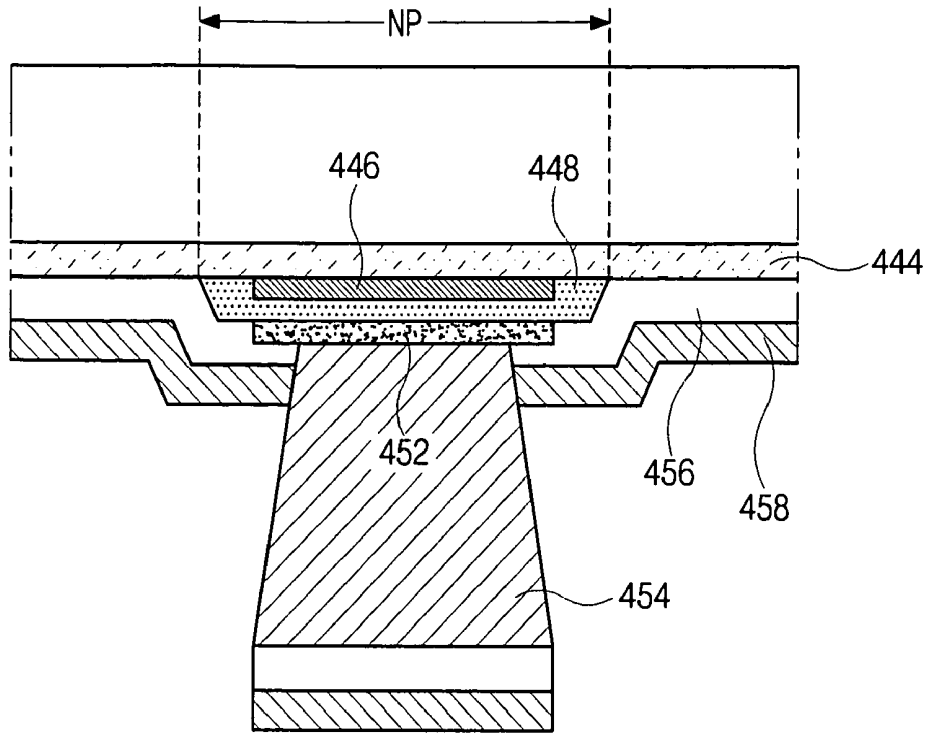

FIG. 9

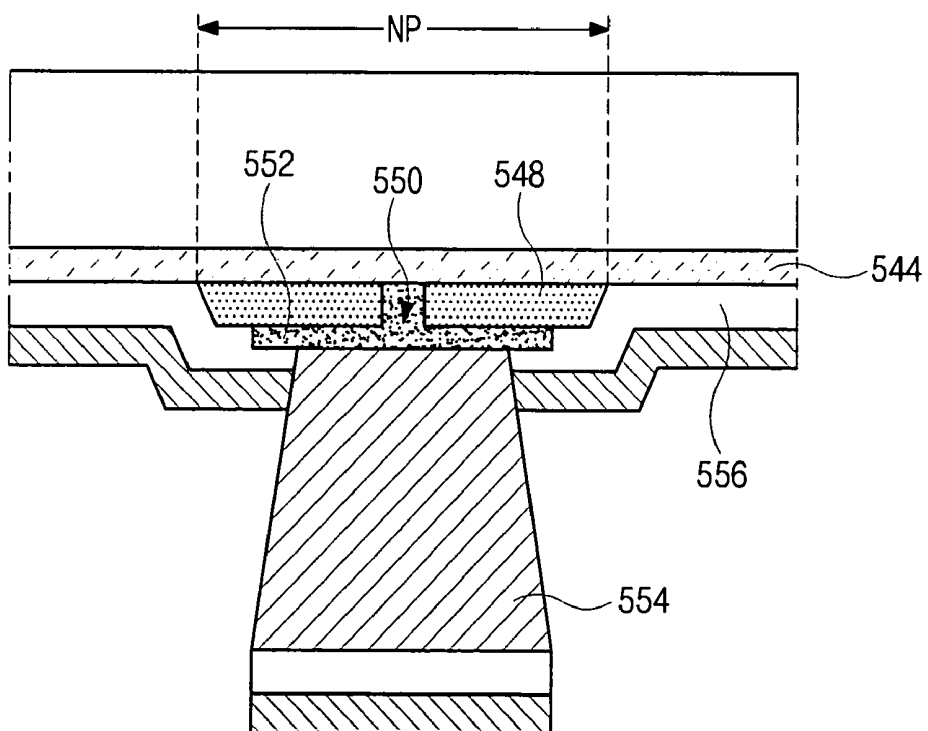

FIG. 10

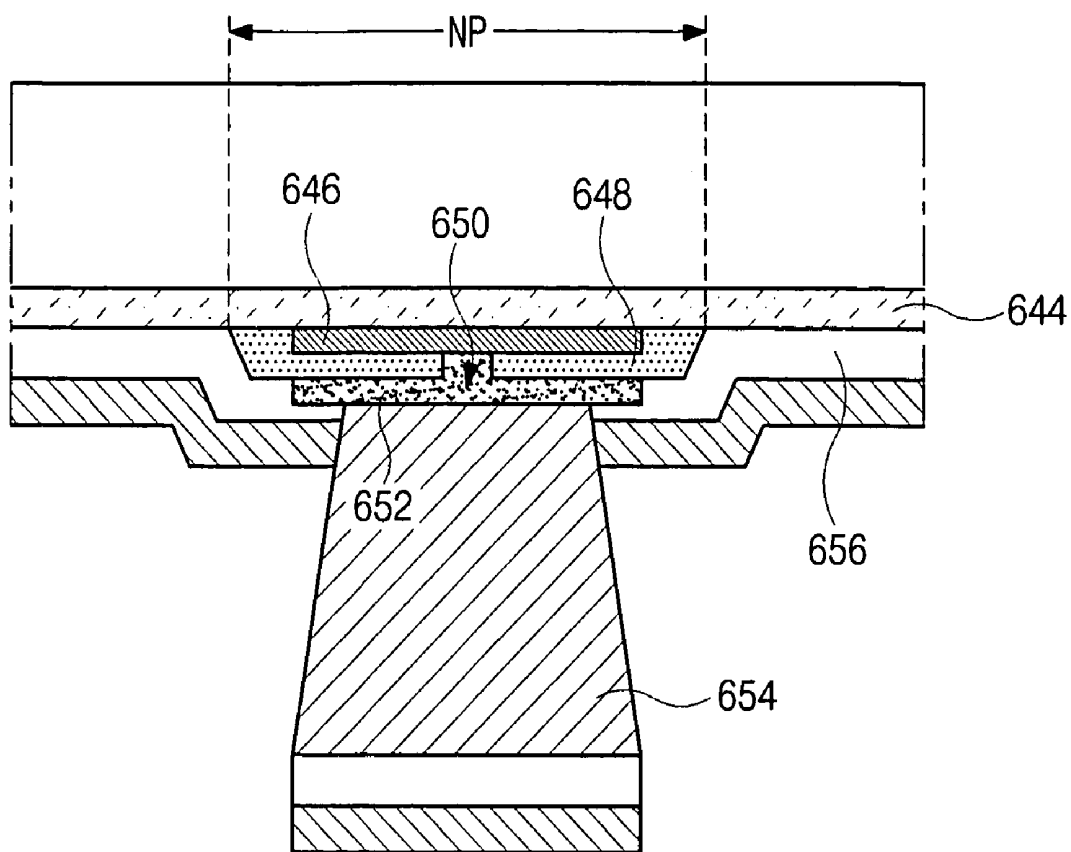

FIG. 11

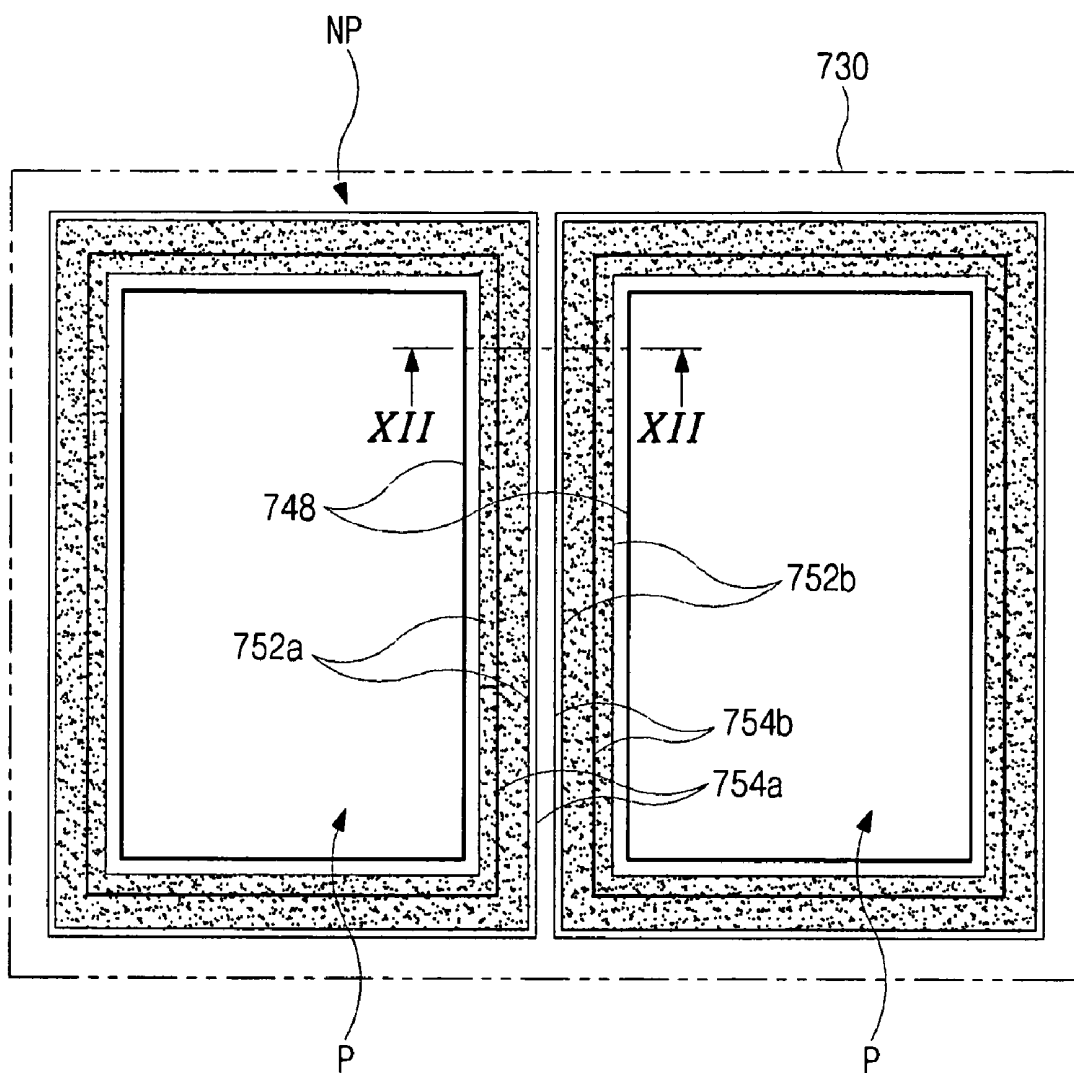

FIG. 12

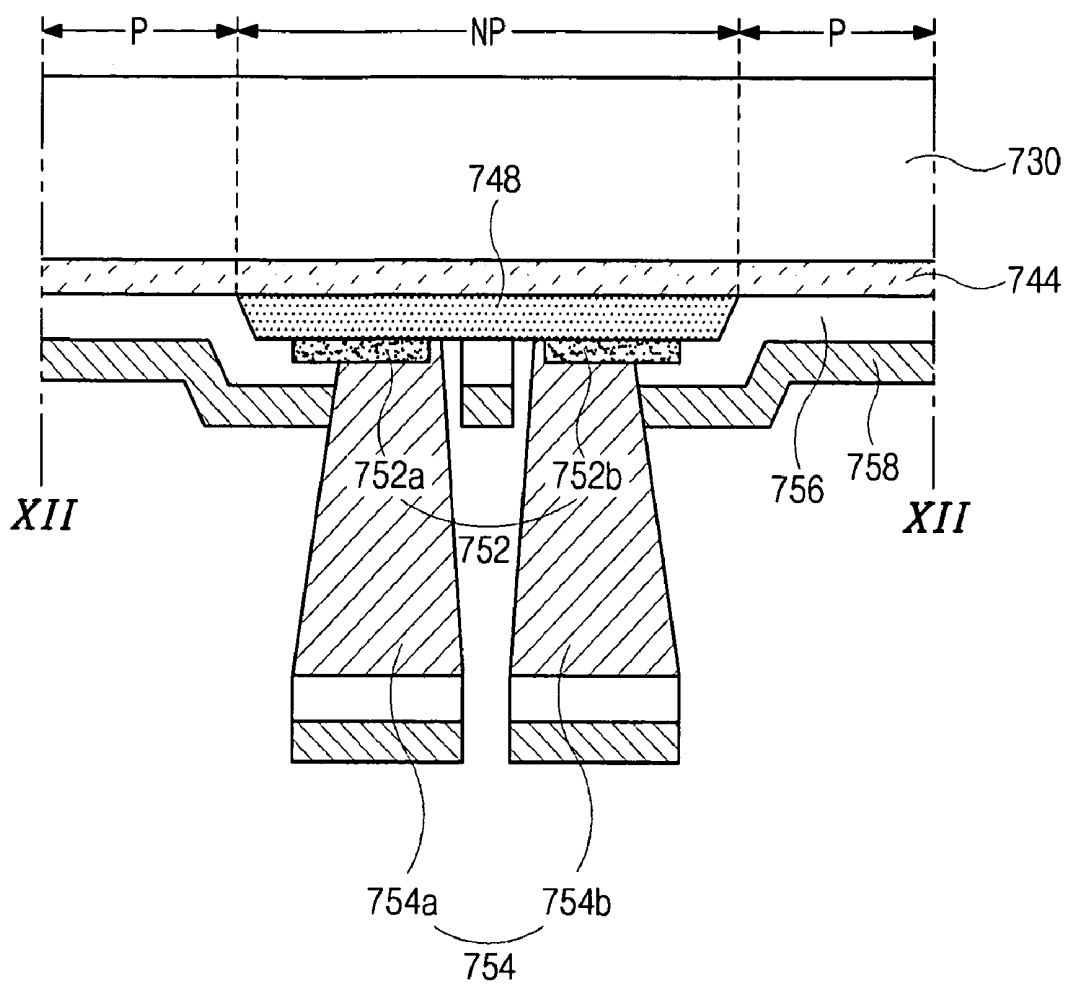

FIG. 13A

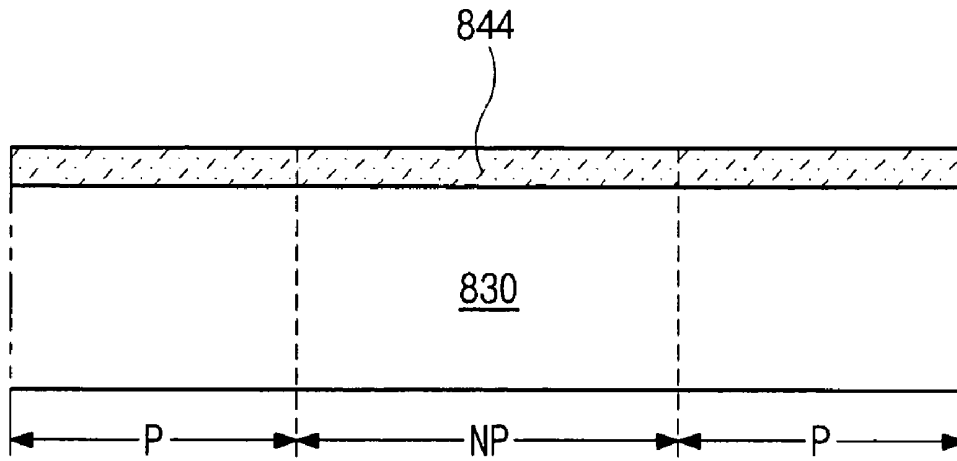

FIG. 13B

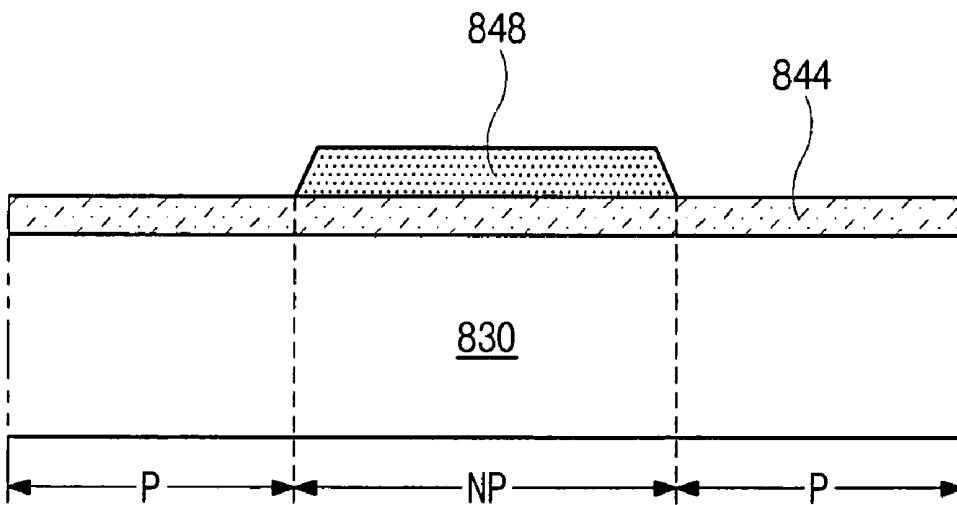

FIG. 13C

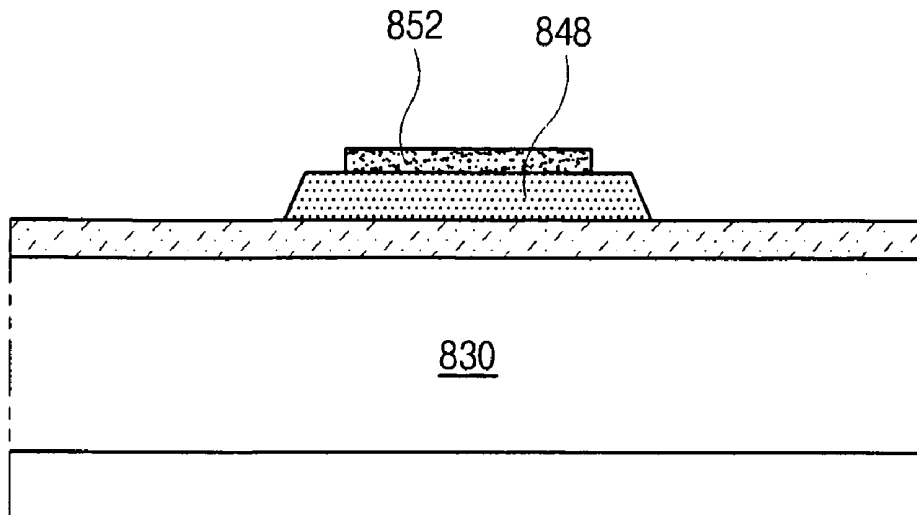

FIG. 13D

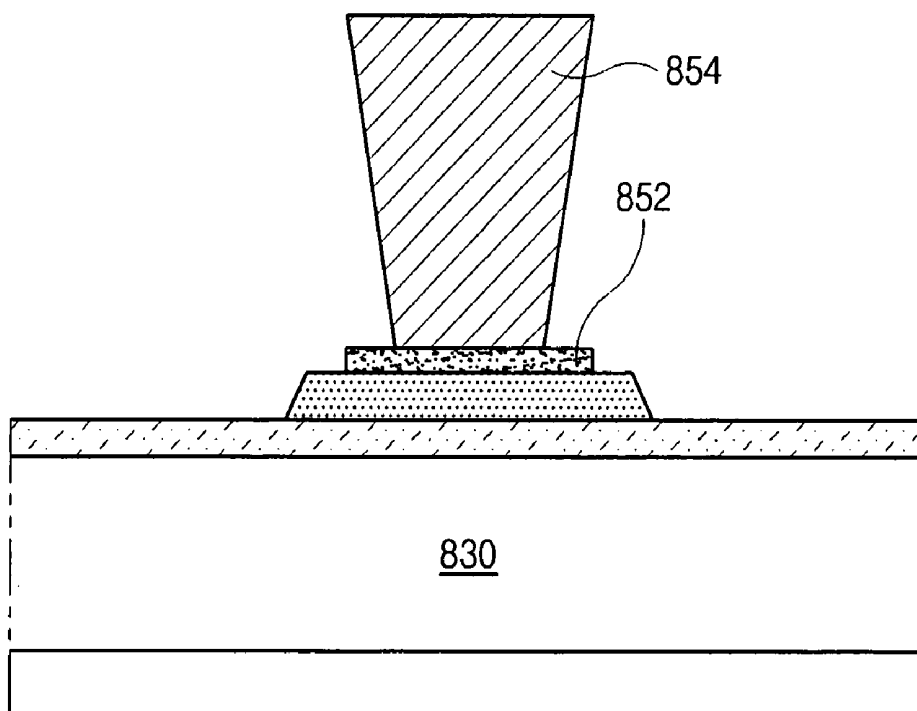
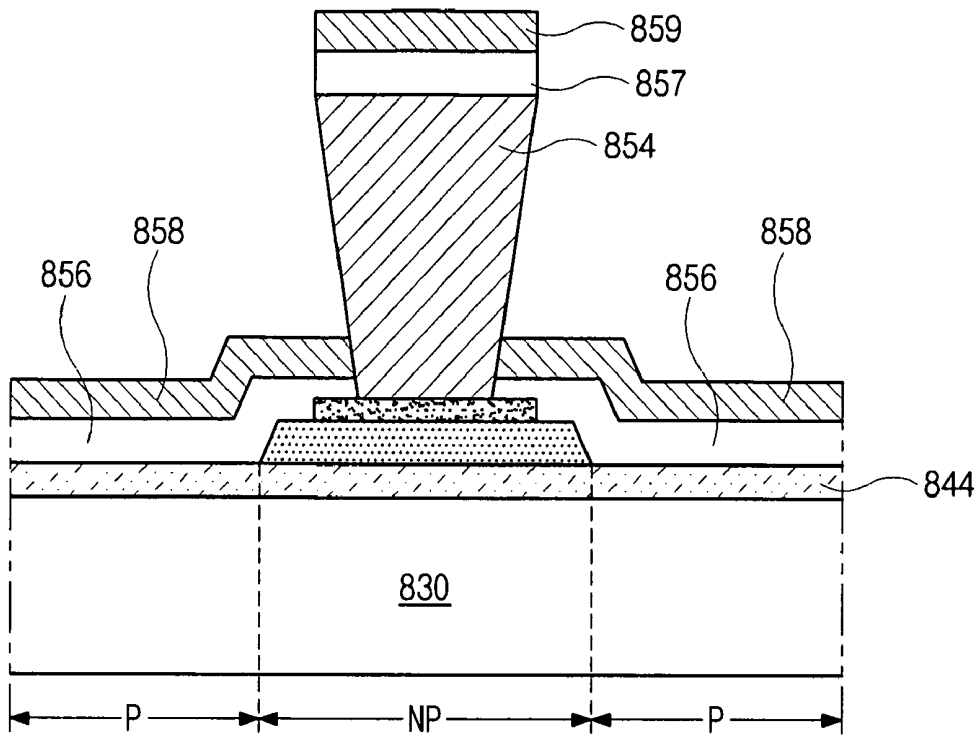

FIG. 13E



ORGANIC ELECTROLUMINESCENT DISPLAY DEVICE AND FABRICATING METHOD THEREOF

[0001] This application is a Divisional of application Ser. No. 11/107,875, filed Apr. 18, 2005 now allowed; which claims priority to Korean Patent Application No. 10-2004-0026571, filed Apr. 19, 2004, all of which are hereby incorporated by reference as if fully set forth herein.

BACKGROUND OF THE INVENTION

[0002] 1. Field of the Invention

[0003] The present invention relates to a display device and a method of fabricating a display device, and more particularly, to an organic electroluminescent display (OLED) device and a method of fabricating an OLED device.

[0004] 2. Discussion of the Related Art

[0005] In the past, many display devices have employed cathode-ray tubes (CRTs) to display images. However, various types of flat panel displays, such as liquid crystal display (LCD) devices, plasma display panel (PDP) devices, field emission display (FED) devices, and electro-luminescent display (ELD) devices, are currently being developed as substitutes for the CRTs. Among these various types of flat panel displays, the PDP devices have advantages of large display size, but have disadvantages of heaviness and high power consumption. Similarly, the LCD devices have advantages of thin profile and low power consumption, but have disadvantages of small display size. However, the OLED devices are luminescent displays having advantages of fast response time, high brightness, and wide viewing angles.

[0006] FIG. 1 is a cross-sectional view of an OLED device according to the related art.

[0007] As illustrated in FIG. 1, an OLED device includes first and second substrates 10 and 60 facing each other and bonded together with a sealant 70. The first substrate 10 includes a thin film transistor T, an array layer AL and an organic emitting diode E including a first electrode 48 and an organic emitting layer 54 within a pixel region P, and a second electrode 56. The second substrate 60 has a recessed portion 62 filled with a desiccant 64 for blocking entry of outer moisture.

[0008] In FIG. 1, when the first electrode 48 is formed of a transparent material, light emitted from the organic emitting layer 54 is transmitted toward the first substrate 10. Thus, this OLED device is categorized as a bottom emission-type OLED device.

[0009] FIG. 2A is a plan view of a pixel region of an OLED device according to the related art, and FIG. 2B is a cross-sectional view, which shows a driving thin film transistor, taken along a line IIb-IIb of FIG. 2A.

[0010] As illustrated in FIG. 2A, in a pixel region P of a first substrate 10, a data line 42 and a gate line 22 crossing each other, a switching thin film transistor Ts, a driving thin film transistor Td, a power line 28 and an organic emitting diode E.

[0011] As illustrated in FIG. 2B, a buffer layer 12 is disposed on a first substrate 10. A semiconductor pattern 14 and a first capacitor electrode 16 is disposed on the buffer layer 12. A gate insulating layer 18 and a gate electrode 20 is disposed on the semiconductor pattern 14. The semiconductor pattern 14 includes an active region AR at a center portion, a drain region DR at a left portion and a source region at a right portion SR.

[0012] A first passivation layer 24 is disposed on the gate electrode 20. A power electrode 26 as a second capacitor electrode extended from the power line 28 is disposed on the first passivation layer 24 corresponding to the first capacitor electrode 16. The power electrode 26 as the second capacitor electrode and the first capacitor electrode 16 define a storage capacitor Cst.

[0013] A second passivation layer 30 is disposed on the power electrode 26. The first and second passivation layers 24 and 30 have first and second contact holes 32 and 34 exposing the source and drain regions SR and DR. Furthermore, the second passivation layer 30 have a third contact hole 36 exposing the power electrode 26.

[0014] Source and drain electrodes 38 and 40 are disposed on the second passivation layer 30. The source and drain electrodes 38 and 40 contact the source and drain regions SR and DR through the first and second contact hole 32 and 34, respectively. Furthermore, the source electrode 38 contacts the power electrode 26 through the third contact hole 36. A third passivation layer 44 is disposed on the source and drain electrodes 38 and 40 and has a fourth contact hole 46 exposing the drain electrode 40.

[0015] An organic emitting diode E including a first electrode 48, an organic emitting layer 54 and a second electrode 56 is disposed on the third passivation layer 44. The first electrode 48 is disposed on the third passivation layer 44 and contacts the drain electrode 40 through the fourth contact hole 46. An inter layer 50 covers an end portion of the first electrode 48 and has an opening 51 exposing the first electrode 48. The organic emitting layer 54 covers the opening 51 and a portion of the inter layer 50. The second electrode 56 is disposed entirely on the substrate 10 having the organic emitting layer 54.

[0016] In the related art OLED device, because the switching and driving thin film transistors and the organic emitting diode are both formed on the first (lower) substrate, the production efficiency of the OLED device is reduced. For example, when one of the switching and driving thin film transistors and the organic emitting diode is determined to have a defect after fabrication, then the first (lower) substrate is considered unacceptable, and thus the production efficiency of the OLED device is reduced. Furthermore, when the OLED device is a bottom emission-type OLED device in which the first electrode of the organic emitting diode is formed of a transparent material, the aperture ratio of the OLED device is reduced and high resolution is difficult to achieve, because the switching and driving thin film transistors and metal lines block bottom emission of the light.

SUMMARY OF THE INVENTION

[0017] Accordingly, the present invention is directed to an OLED device and a method of fabricating an OLED device that substantially obviate one or more of problems due to limitations and disadvantages of the related art.

[0018] An advantage of the present invention is to provide an OLED device which can have an improved aperture ratio and high resolution.

[0019] Another advantage of the present invention is to provide a method of fabricating an OLED device which can have improved production efficiency.

[0020] Additional features and advantages of the invention will be set forth in the description which follows, and in part will be apparent from the description, or may be learned by practice of the invention. The advantages of the invention will

be realized and attained by the structure particularly pointed out in the written description and claims hereof as well as the appended drawings.

[0021] To achieve these and other advantages and in accordance with the purpose of the present invention, as embodied and broadly described, an electroluminescent display device includes first and second substrates facing each other and having a pixel region and a non-pixel region; a thin film transistor and an array layer on an inner surface of the first substrate; a first electrode on an inner surface of the second substrate; a buffer layer on the first electrode in the non-pixel region; a shielding pattern on the buffer layer; a separator on the shielding pattern; an emitting layer on the first electrode in the pixel region; a second electrode on the emitting layer; and a connection electrode between the first and second substrates.

[0022] In another aspect, a method of fabricating a substrate for an electroluminescent display device includes forming a first electrode on a substrate having a pixel region and a non-pixel region; forming a buffer layer on the first electrode in the non-pixel region; forming a shielding pattern on the buffer layer; forming a separator on the shielding pattern; forming an emitting layer on the first electrode in the pixel region; and forming a second electrode on the emitting layer.

[0023] It is to be understood that both the foregoing general description and the following detailed description are exemplary and explanatory and are intended to provide further explanation of the invention as claimed.

BRIEF DESCRIPTION OF THE DRAWINGS

[0024] The accompanying drawings, which are included to provide a further understanding of the invention and are incorporated in and constitute a part of this specification, illustrate embodiments of the invention and together with the description serve to explain the principles of the invention.

[0025] In the drawings:

[0026] FIG. 1 is a cross-sectional view of an OLED device according to the related art;

[0027] FIG. 2A is a plan view of a pixel region of an OLED device according to the related art;

[0028] FIG. 2B is a cross-sectional view, which illustrates a driving thin film transistor, taken along a line IIb-IIb of FIG. 2A;

[0029] FIG. 3 is a cross sectional view of an OLED device according to a first embodiment of the present invention;

[0030] FIG. 4 is a plan view of an OLED device according to a second embodiment of the present invention;

[0031] FIG. 5 is a cross-sectional view taken along a line V-V of FIG. 4;

[0032] FIG. 6 is a cross-sectional view of an OLED device according to a third embodiment of the present invention;

[0033] FIG. 7 is a cross-sectional view of an OLED device according to a fourth embodiment of the present invention;

[0034] FIG. 8 is a cross-sectional view of an OLED device according to a fifth embodiment of the present invention;

[0035] FIG. 9 is a cross-sectional view of an OLED device according to a sixth embodiment of the present invention;

[0036] FIG. 10 is a cross-sectional view of an OLED device according to a seventh embodiment of the present invention;

[0037] FIG. 11 is a plan view of an OLED device according to an eighth embodiment of the present invention;

[0038] FIG. 12 is a cross-sectional view taken along a line XII-XII of FIG. 11; and

[0039] FIGS. 13A to 13E are cross-sectional views of a method of fabricating an OLED device according to the present invention.

DETAILED DESCRIPTION OF THE ILLUSTRATED EMBODIMENTS

[0040] Reference will now be made in detail to embodiments of the present invention, examples of which are illustrated in the accompanying drawings.

[0041] FIG. 3 is a cross-sectional view of an OLED device according to a first embodiment of the present invention.

[0042] As illustrated in FIG. 3, an OLED device includes first and second substrates **110** and **130** facing each other and bonded together by a sealant **180**. In the OLED device, a pixel region P displaying images and a non-pixel region NP disposed between adjacent pixel regions NP are defined.

[0043] The first substrate **110** includes a thin film transistor T and an array layer AL disposed on the inner surface of the first substrate **110**. The thin film transistor T is disposed in the pixel region P and connected to the array layer AL. Though not shown in drawings, the thin film transistor T may have a gate electrode, source and drain electrodes and a semiconductor pattern, as illustrated in FIG. 2A. The thin film transistor T may correspond to switching and driving thin film transistors. Though not shown in the drawings, the array layer AL may include conductive patterns such as gate and data lines defining the pixel region P and a power line.

[0044] The second substrate **130** includes an organic emitting diode E, a buffer layer **148** and a separator **154** on the inner surface of the second substrate **130**. The organic emitting diode E includes a first electrode **144** on the second substrate **130**, and an organic emitting layer **156** and a second electrode **158** on the first electrode **144** in the pixel region P. The first electrode **144** as an anode may be formed of a transparent conductive material such as indium-tin-oxide (ITO), indium-zinc-oxide (IZO) or the like. The second electrode **144** as a cathode may be formed of an opaque conductive material (i.e., metal) or the like. The organic emitting layer **156** may include an emitting material layer (EML), a hole injection layer (HIL) disposed between the first electrode **144** and the emitting material layer, and an electron injection layer (EIL) disposed between the second electrode **158** and the emitting material layer. When the first electrode **144** is formed of a transparent material, light emitted from the organic emitting layer **156** can travel toward the second substrate **130**. Accordingly, the OLED device of FIG. 3 may be categorized as a top-emission type OLED device due to the light emission direction.

[0045] The buffer layer **148** and the separator **154** are disposed sequentially on the first electrode **144** in the non-pixel region NP. Since the separator **154** is disposed between adjacent pixel regions P, the separator **120** separates the organic emitting layer **156** and the second electrode **158**. The buffer layer **148** acts as a means for preventing the first and second electrodes **144** and **158** from contacting each other.

[0046] A connection pattern **120** is disposed between the first and second substrates **110** and **130**, and thus connects the thin film transistor T and the second electrode **158**.

[0047] In the OLED device of the first embodiment, the thin film transistor T and the organic emitting diode E are respectively formed on the different substrates **110** and **130**. Therefore, the production efficiency of the OLED device can increase. Further, in the top emission type OLED, the light emitted from the organic emitting layer **156** can travel toward

the second substrate 130 facing the first substrate 110, where the thin film transistor T and metal lines blocking light emission are disposed. Therefore, the aperture ratio of the OLED device can increase, thereby achieving a high resolution.

[0048] As above explained, the light emitted from the organic emitting layer 156 travels toward the second substrate 130. However, portions of the emitted light may travel toward the first substrate 110 through the transparent separator 154, as shown with a dashed arrow of FIG. 3. This abnormal light traveling toward the first substrate 110 may cause a current leakage of the thin film transistor T when amorphous silicon is used for the semiconductor pattern of the thin film transistor T.

[0049] Next, a second embodiment of the present invention will be described as an improvement of the first embodiment as shown in FIG. 3.

[0050] FIG. 4 is a plan view of an OLED device according to a second embodiment of the present invention, and FIG. 5 is a cross-sectional view taken along a line V-V of FIG. 4. Detailed explanation of the similar parts to the first embodiment will be omitted.

[0051] As illustrated in FIGS. 4 and 5, an OLED device further includes a shielding pattern 252 disposed between a buffer layer 248 and a separator 254. The shielding pattern 252 shields the abnormal light emitted from an organic emitting layer 256 and traveling toward the first substrate (not shown) through the separator 254, which is shown with a dashed arrow of FIG. 5. The shielding pattern 252 may be formed of a light shielding insulating material such as a black resin.

[0052] The buffer layer 248 has a first width W1, the shielding pattern 252 has a second width W2, and the separator 254 has a third width W3 at a contacting portion between the separator 254 and the shielding pattern 252. The first width W1 may be greater than the second width W2, and the second width W2 may be greater than the third width W3.

[0053] First and second dummy layers 257 and 259 are disposed sequentially on the separator 254. The first dummy layer 257 is formed of the same material as the organic emitting layer 256, and the second dummy layer 259 is formed of the same material as the second electrode 258. The organic emitting layer 256 and the second electrode 258 are formed after forming the separator 254. Accordingly, the first and second dummy layers 257 and 259 are formed on the separator 254 when the organic emitting layer 256 and the second electrode 258 are formed. The OLED device of the second embodiment can be effectively applied to an OLED device having a size under fifteen inches.

[0054] FIG. 6 is a cross-sectional view of an OLED device according to a third embodiment of the present invention. The third embodiment relates to an OLED device capable of displaying colors. Detailed explanation of the similar parts to the first and second embodiments will be omitted. The OLED device of the third embodiment is similar to that of the second embodiment, except for a color displaying means.

[0055] As illustrated in FIG. 6, the OLED device includes a color filter pattern 334 as well as a shielding pattern 352. The color filter pattern 334 as a color displaying means is disposed on a second substrate 330. The color filter pattern 334 may further include red (R), green (G) and blue (B) color filter patterns 334a, 334b and 334c in respective pixel regions P. The red (R), green (G) and blue (B) color filter patterns 334a, 334b and 334c may be formed of red, green and blue color resins, respectively.

[0056] A black matrix 336 is disposed in a non-pixel region NP between adjacent pixel regions P. The black matrix 336 may correspond to metal lines such as gate and data lines. A planarization layer 340 and a barrier layer 342 are disposed between the color filter pattern 334 and a first electrode 344. The planarization layer 340 planarizes the second substrate 330 having the color filter patterns 334. The barrier layer 342 prevents the color filter pattern 334 from outgassing and stabilizes elements deposited thereon. The shielding pattern 352 may be disposed between a buffer layer 348 and a separator 354, similarly to that of the second embodiment.

[0057] As above explained, the color filter patterns 334 are disposed on the inner surface of the second substrate 330. However, it should be understood that the arrangement of the color filter patterns 334 in the OLED device is not limited to, and that various modifications are feasible according to the principles of the present invention.

[0058] In the third embodiment, the OLED device can display color images through the color filter patterns 334. Accordingly, an organic emitting layer 356 may emit a single color, for example, a white color.

[0059] In the third embodiment, the OLED device includes the color filter patterns as a color displaying means. However, it should be understood that a color changing medium (CCM) disposed between the second substrate and the color filter patterns can be further used as a color displaying means.

[0060] FIG. 7 is a cross-sectional view of an OLED device according to a fourth embodiment of the present invention. The fourth embodiment relates to an OLED device displaying colors as in the third embodiment. Detailed explanation of the similar parts to the first to third embodiments will be omitted.

[0061] As illustrated in FIG. 7, the OLED device includes organic emitting layers 357 as a color displaying means including red (R), green (G) and blue (B) emitting layers 357a, 357b and 357c in respective pixel regions P between adjacent separators 354. The red (R), green (G) and blue (B) emitting layers 357a, 357b and 357c are used as a color display means instead of the color filter patterns 334 of the third embodiment.

[0062] FIG. 8 is a cross-sectional view of an OLED device according to a fifth embodiment of the present invention. Detailed explanation of the similar parts to the first to fourth embodiments will be omitted. The OLED device of the fifth embodiment is similar to that of the second embodiment, except for a resistance reducing means.

[0063] As illustrated in FIG. 8, the OLED device includes an auxiliary electrode 446 as a resistance reducing means in a non-pixel region P. The auxiliary electrode 446 contacts a first electrode 444 and is disposed between the first electrode 444 and a buffer layer 448 in a non-pixel region NP. Since the first electrode 444 is formed of a transparent conductive material such as indium-tin-oxide (ITO), the first electrode 444 has a high resistance compared with metal. In particular, when the OLED device has a large size more than fifteen inches, the high resistance of the first electrode 444 causes electrical problems. Accordingly, to reduce the resistance of the first electrode 444, the auxiliary electrode 446 having a resistance lower than the first electrode 444 is used. The auxiliary electrode 446 may be formed of a material that can prevent galvanic corrosion with the first electrode 444. In other words, the auxiliary electrode 446 may not be formed of a material including aluminum (Al), because a material including aluminum may create a galvanic corrosion problem when

used in association with the first electrode **444** formed of ITO. Instead, molybdenum (Mo) may be used for the material of the auxiliary electrode **446**.

[0064] On the buffer layer **448**, a shielding pattern **452** and a separator **454** are disposed. Between adjacent separators **454**, an organic emitting layer **456** and a second electrode **458** are disposed.

[0065] FIG. 9 is a cross-sectional view of an OLED device according to a sixth embodiment of the present invention. Detailed explanation of the similar parts to the first to fifth embodiments will be omitted. The OLED device of the sixth embodiment is similar to that of the fifth embodiment, except for structures of a resistance reducing means and a shielding pattern.

[0066] As illustrated in FIG. 9, the OLED device includes a shielding pattern **552** acting as both a light shielding means and a resistance reducing means in a non-pixel region NP. The shielding pattern **552** is disposed between a buffer layer **548** and a separator **554** to shield light, similarly to that of the second embodiment. Furthermore, the shielding pattern **552** having a resistance lower than the first electrode **544** contacts a first electrode **544** to reduce a resistance of the first electrode **544**, similarly to the auxiliary electrode of the fifth embodiment.

[0067] The buffer layer **548** has a contact hole **550** to contact the shielding pattern **552** and the first electrode **544**. Since the shielding pattern **552** acts as a resistance reducing means, the shielding pattern **552** may be formed of a conductive material. In particular, the shielding pattern **552** may be formed of a material that can prevent galvanic corrosion with the first electrode **544**, for example, molybdenum (Mo), as explained in the fifth embodiment. Between adjacent separators **554**, an organic emitting layer **556** is disposed.

[0068] FIG. 10 is a cross-sectional view of an OLED device according to a seventh embodiment of the present invention. Detailed explanation of the similar parts to the first to sixth embodiments will be omitted. The OLED device of the seventh embodiment is similar to that of the fifth and sixth embodiments, except for structures of a resistance reducing means and a shielding pattern.

[0069] As illustrated in FIG. 10, the OLED device includes a shielding pattern **652** and an auxiliary electrode **646** contacting each other in a non-pixel region NP. The auxiliary electrode **646** contacts a first electrode **644** and is disposed between the first electrode **644** and a buffer layer **648**, similarly to that of the fifth embodiment. Thus, the auxiliary electrode **646** reduces a resistance of the first electrode **644**. The shielding pattern **652** is disposed between the buffer layer **648** and a separator **654** to shield light and contacts the auxiliary electrode **646**, similarly to that of the sixth embodiment.

[0070] The buffer layer **648** has a contact hole **650** to contact the shielding pattern **652** and the auxiliary electrode **646**, similarly to that of the sixth embodiment. As explained in the fifth and sixth embodiments, the shielding pattern **652** may be formed of a conductive material that can prevent galvanic corrosion with the first electrode **644**, for example, molybdenum (Mo). Between adjacent separators **654**, an organic emitting layer **656** is disposed.

[0071] FIG. 11 is a plan view of an OLED device according to an eighth embodiment of the present invention, and FIG. 12 is a cross-sectional view taken along a line XII-XII of FIG. 11. Detailed explanation of the similar parts to the first to seventh embodiments will be omitted. The OLED device of the eighth

embodiment is similar to that of the second embodiment, except for structures of a shielding pattern and a separator.

[0072] As illustrated in FIGS. 11 and 12, the OLED device includes a shielding pattern **752** and a separator **754** having double-patterned structures. In other words, the shielding pattern **752** includes a first pattern **752a** and a second pattern **752b** on both side portions of a buffer layer **748**, and the separator **754** includes a first sub-separator **754a** and a second sub-separator **754b** on the first pattern **752a** and the second pattern **752b**, respectively.

[0073] Width relations of the buffer layer **748**, the shielding pattern **752** and the separator **754** are similar to those of the second embodiment. In other words, a width of a portion of the buffer layer **748** corresponding to the first pattern **752a** is greater than that of the first pattern **752a**, and the width of the first pattern **752a** is greater than that of the first sub-separator **754a** at a contacting portion between the first sub-separator **754a** and the first pattern **752a**. Furthermore, a width of a portion of the buffer layer **748** corresponding to the second pattern **752b** is greater than that of the second pattern **752b**, and the width of the second pattern **752b** is greater than that of the second sub-separator **754b** at a contacting portion between the second sub-separator **754b** and the second pattern **752b**.

[0074] In the eighth embodiment, since the separator **754** includes the first and second sub-separators **754a** and **754b** in a non-pixel region NP, the separator **754** can effectively separate adjacent pixel regions P.

[0075] FIGS. 13A to 13E are cross-sectional views of a method of fabricating an OLED device according to the present invention. Although a method of fabricating the OLED device of the second embodiment will be explained, it should be understood that a fabricating method according to the present invention can vary and it can be applied to fabricating methods of the OLED devices of the first embodiment and the third to eighth embodiments with minor variations.

[0076] As illustrated in FIG. 13A, a first electrode **844** is formed on a substrate **830** having pixel and non-pixel regions P and NP. The first electrode **844** may be formed of a transparent conductive material such as indium-tin-oxide (ITO) and indium-zinc-oxide (IZO).

[0077] As illustrated in FIG. 13B, a buffer layer **848** is formed on the first electrode **844** in the non-pixel region NP.

[0078] As illustrated in FIG. 13C, a shielding pattern **852** is formed on the buffer layer **848**. A width of the buffer layer **848** may be greater than a width of the shielding pattern **852**. As explained in the second to eighth embodiments, the shielding pattern **852** may be formed of a light shielding material. In particular, when the OLED device has a large size, the light shielding material can be selected from conductive materials such as metal, especially when the shielding pattern contacts the first electrode or the auxiliary electrode, as shown in FIG. 9 or 10. However, when the shielding pattern does not connect to the first electrode as shown in FIG. 8, the light shielding material may not be a conductor. In such a case, a black resin can also be used for the light shielding material.

[0079] As illustrated in FIG. 13D, a separator **854** is formed on the shielding pattern **852**. A width of the shielding pattern **852** may be greater than a width of the separator **854** at a contacting portion between the shielding pattern **852** and the separator **854**.

[0080] As illustrated in FIG. 13E, first and second dummy layers **857** and **859** are formed on the separator **854**, and an

organic emitting layer **856** and a second electrode **858** are formed sequentially on the first electrode **844** in the pixel region P.

[0081] It will be apparent to those skilled in the art that various modifications and variations can be made in the OLED device and method fabricating an OLED device without departing from the spirit or scope of the invention. Thus, it is intended that the present invention cover the modifications and variations of this invention provided they come within the scope of the appended claims and their equivalents.

What is claimed is:

1. An electroluminescent display device, comprising:
 - first and second substrates facing each other and having a pixel region and a non-pixel region;
 - a thin film transistor and an array layer on an inner surface of the first substrate;
 - a first electrode on an inner surface of the second substrate;
 - a buffer layer on an inner surface of the first electrode in the non-pixel region;
 - a shielding pattern on an inner surface of the buffer layer;
 - a separator on an inner surface of the shielding pattern;
 - an emitting layer on the inner surface of the first electrode in the pixel region;
 - a second electrode on an inner surface of the emitting layer;
 - a connection electrode between the first and second substrates; and
 - a color filter pattern between the second substrate and the first electrode,
 wherein the buffer layer has a contact hole, and the first electrode and the shielding pattern are connected through the contact hole.
2. The device according to claim 1, further comprising a color changing medium between the second substrate and the color filter pattern.
3. The device according to claim 1, further comprising a planarization layer and a barrier layer between the color filter pattern and the first electrode.
4. The device according to claim 1, wherein the color filter pattern includes red, green and blue color filter patterns, and the emitting layer emits a single color.
5. The device according to claim 4, wherein the emitting layer emits a white color.
6. An electroluminescent display device, comprising:
 - first and second substrates facing each other and having a pixel region and a non-pixel region;
 - a thin film transistor and an array layer on an inner surface of the first substrate;
 - a first electrode on an inner surface of the second substrate;
 - a buffer layer on an inner surface of the first electrode in the non-pixel region;
 - a shielding pattern on an inner surface of the buffer layer;

- a separator on an inner surface of the shielding pattern;
- an emitting layer on the inner surface of the first electrode in the pixel region;
- a second electrode on an inner surface of the emitting layer;
- a connection electrode between the first and second substrates; and
- first and second dummy layers on the separator, the first and second dummy layers having the same materials as the emitting layer and the second electrode, respectively, wherein the buffer layer has a contact hole, and the first electrode and the shielding pattern are connected through the contact hole.

7. A method of fabricating a substrate for an electroluminescent display device, comprising:
 - forming a first electrode on a substrate having a pixel region and a non-pixel region;
 - forming a buffer layer on the first electrode in the non-pixel region;
 - forming a shielding pattern on the buffer layer;
 - forming a separator on the shielding pattern;
 - forming an emitting layer on the first electrode in the pixel region;
 - forming a second electrode on the emitting layer; and
 - forming a color filter pattern between the substrate and the first electrode,
 wherein forming the buffer layer includes forming a contact hole exposing the first electrode.
8. The method according to claim 7, further comprising forming a color changing medium between the substrate and the color filter pattern.
9. The method according to claim 7, further comprising forming a planarization layer and a barrier layer between the color filter pattern and the first electrode.
10. A method of fabricating a substrate for an electroluminescent display device, comprising:
 - forming a first electrode on a substrate having a pixel region and a non-pixel region;
 - forming a buffer layer on the first electrode in the non-pixel region;
 - forming a shielding pattern on the buffer layer;
 - forming a separator on the shielding pattern;
 - forming an emitting layer on the first electrode in the pixel region;
 - forming a second electrode on the emitting layer; and
 - forming first and second dummy layers on the separator, the first and second dummy layers having the same materials as the emitting layer and the second electrode, respectively,
 wherein forming the buffer layer includes forming a contact hole exposing the first electrode.

* * * * *

| | | | |
|----------------|--|---------|------------|
| 专利名称(译) | 有机电致发光显示装置及其制造方法 | | |
| 公开(公告)号 | US20090261723A1 | 公开(公告)日 | 2009-10-22 |
| 申请号 | US12/457690 | 申请日 | 2009-06-18 |
| [标]申请(专利权)人(译) | 涌JAE KIM YONG KI BAE盛骏 PARK容 | | |
| 申请(专利权)人(译) | 涌-JAE 金基永 BAE晟准 朴勇 | | |
| 当前申请(专利权)人(译) | LG DISPLAY CO. , LTD. | | |
| [标]发明人 | CHUNG IN JAE KIM KI YONG BAE SUNG JOON PARK JAE YONG | | |
| 发明人 | CHUNG, IN-JAE KIM, KI-YONG BAE, SUNG-JOON PARK, JAE-YONG | | |
| IPC分类号 | H01L27/32 H01L21/02 H05B33/00 H01J29/10 H01L51/52 H05B33/12 | | |
| CPC分类号 | H01L27/322 H01L27/3246 H01L27/3251 H01L2251/5315 H01L27/3276 H01L51/5206 H01L27/3272 H01L51/5212 | | |
| 优先权 | 1020040026571 2004-04-19 KR | | |
| 其他公开文献 | US7902753 | | |
| 外部链接 | Espacenet USPTO | | |

摘要(译)

一种电致发光显示装置，包括彼此面对的第一和第二基板，并具有像素区域和非像素区域；薄膜晶体管 and 第一基板内表面上的阵列层；第二基板内表面上的第一电极；非像素区域中的第一电极上的缓冲层；缓冲层上的屏蔽图案；屏蔽图案上的隔板；像素区域中的第一电极上的发光层；发光层上的第二电极；以及第一和第二基板之间的连接电极。

